

9				10			
ECO NR.	DATE	CHG.	ZONE	DESCRIPTION OF CHANGE	REL.	DR.	CHK.
..
..
..
..
..
..

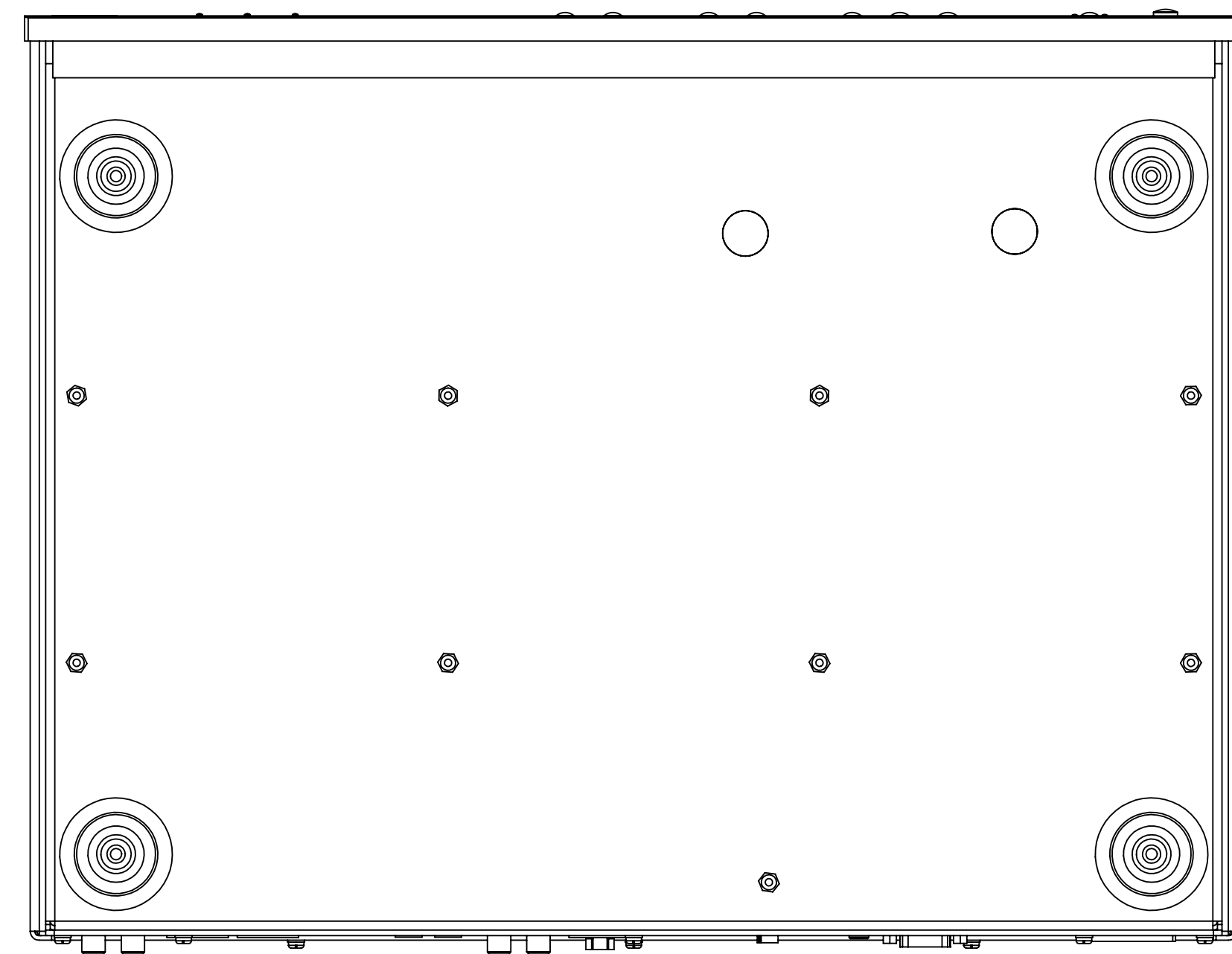

NOTES:
ALLOW ADEQUATE CLEARANCE
AROUND THE PRODUCT FOR
VENTILATION AND CONNECTION

ARCAM A & R CAMBRIDGE LTD LINEAR TOLERANCE +0.2MM UNLESS OTHERWISE STATED ANGULAR TOLERANCE +1° UNLESS OTHERWISE STATED	ALL DIMENSIONS IN MILLIMETERS UNLESS OTHERWISE STATED	DRAWN BY:	
		DATE:	21/12/2011
MATERIAL:		CHECKED BY:	..
FINISH:		ORIGINAL SCALE:	1:2
PART NUMBER AND DRAWING NUMBER			
DRAWING TITLE	D33 ASSEMBLY		
			A1

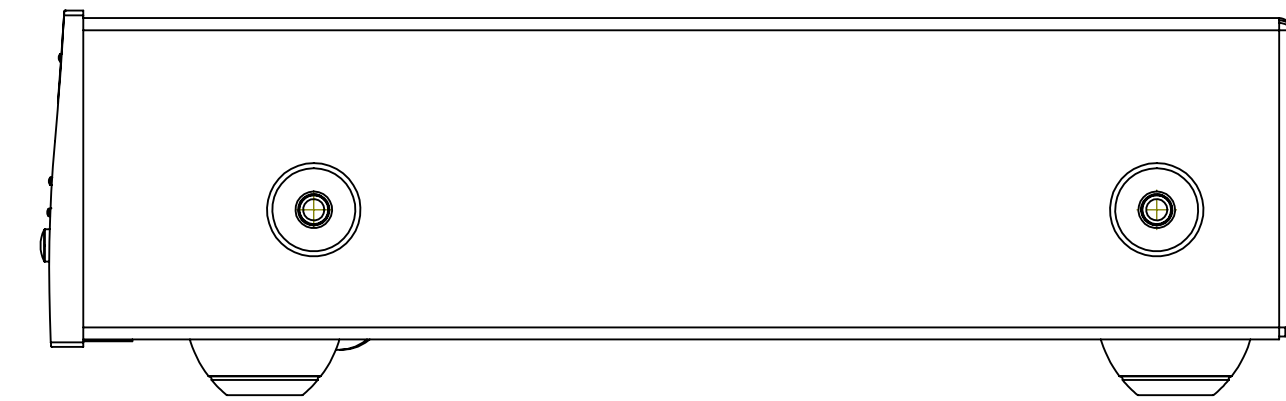
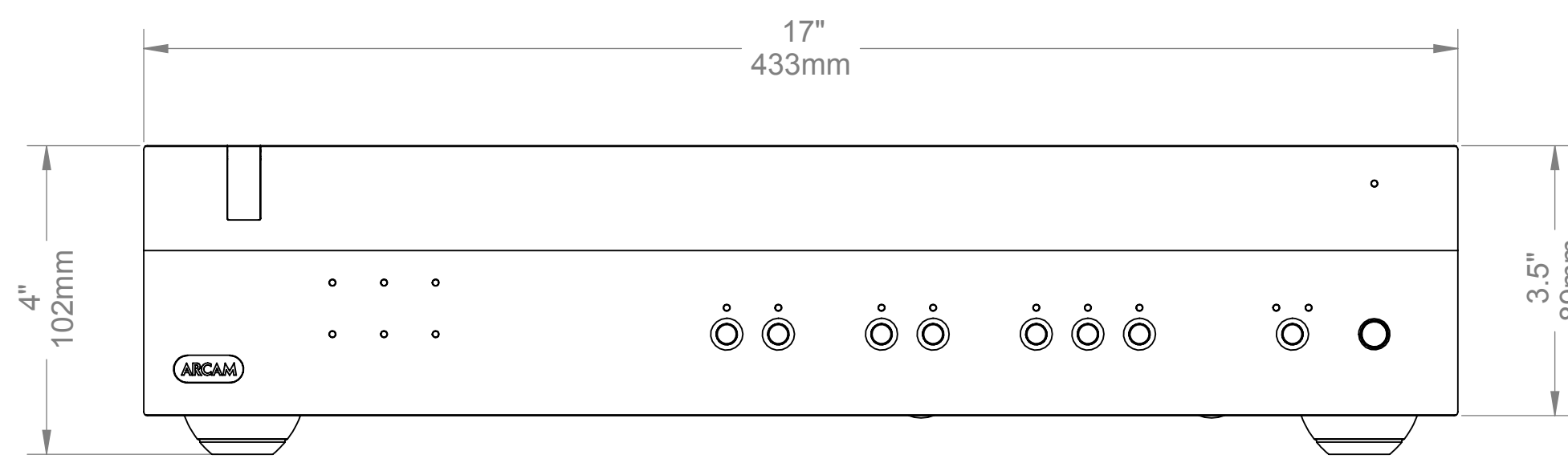
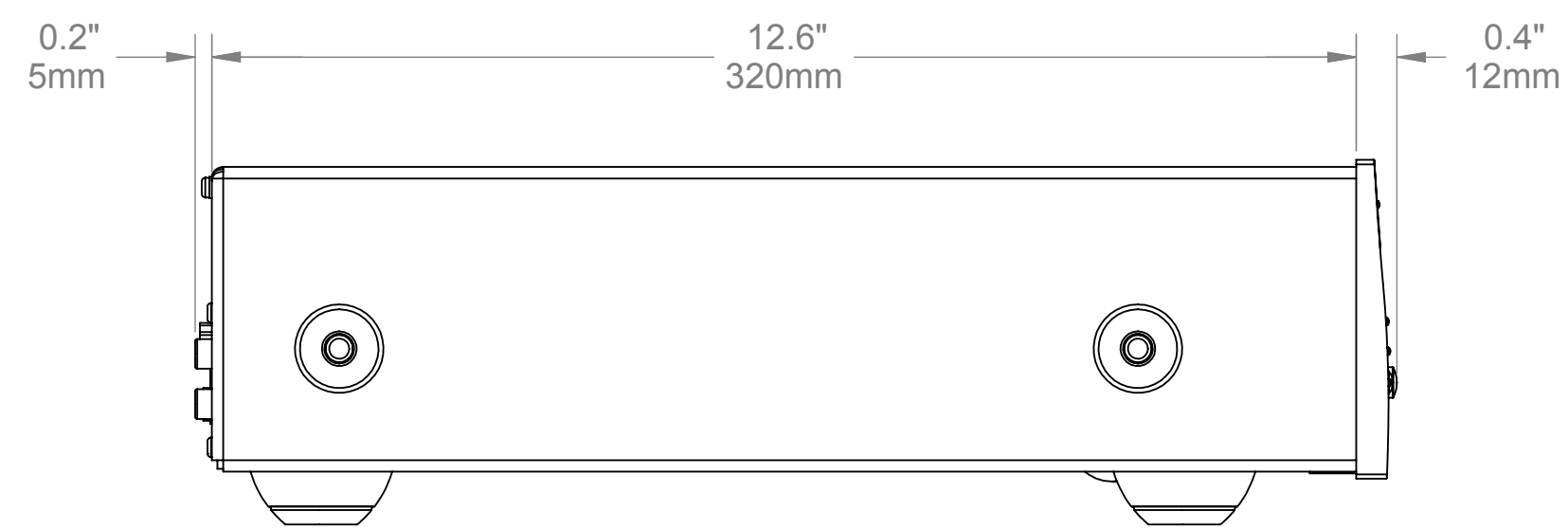
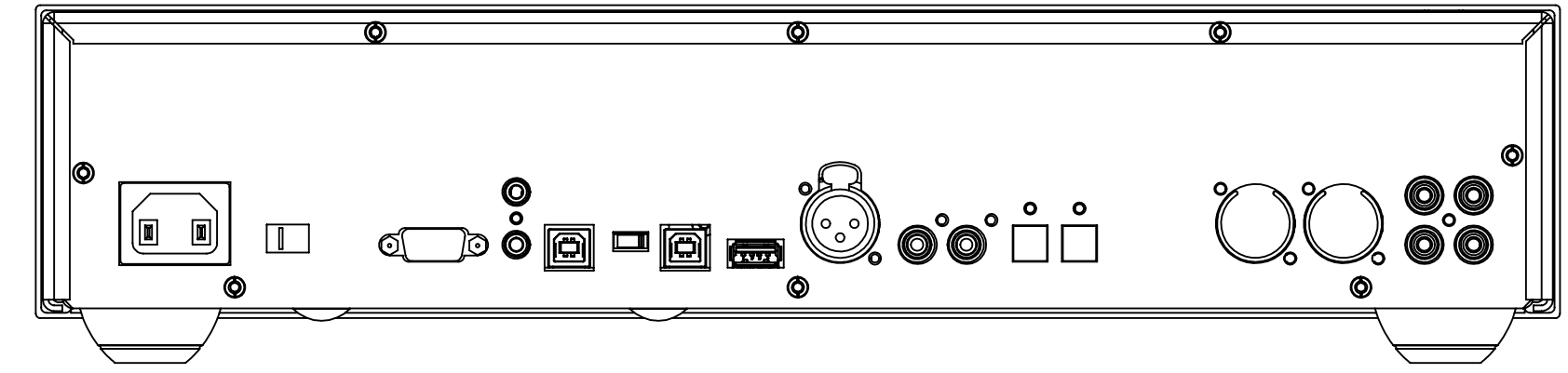