

ECO NR.	DATE	CHG.	ZONE	DESCRIPTION OF CHANGE	REL.	DR.	CHK.
--	--	--	--	--	--	--	--
--	--	--	--	--	--	--	--
--	--	--	--	--	--	--	--
--	--	--	--	--	--	--	--

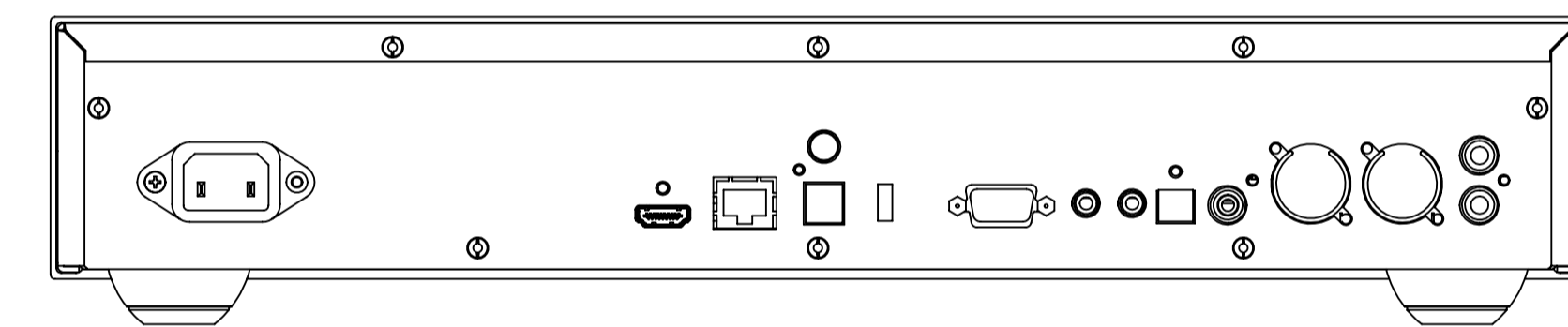

REAR VIEW

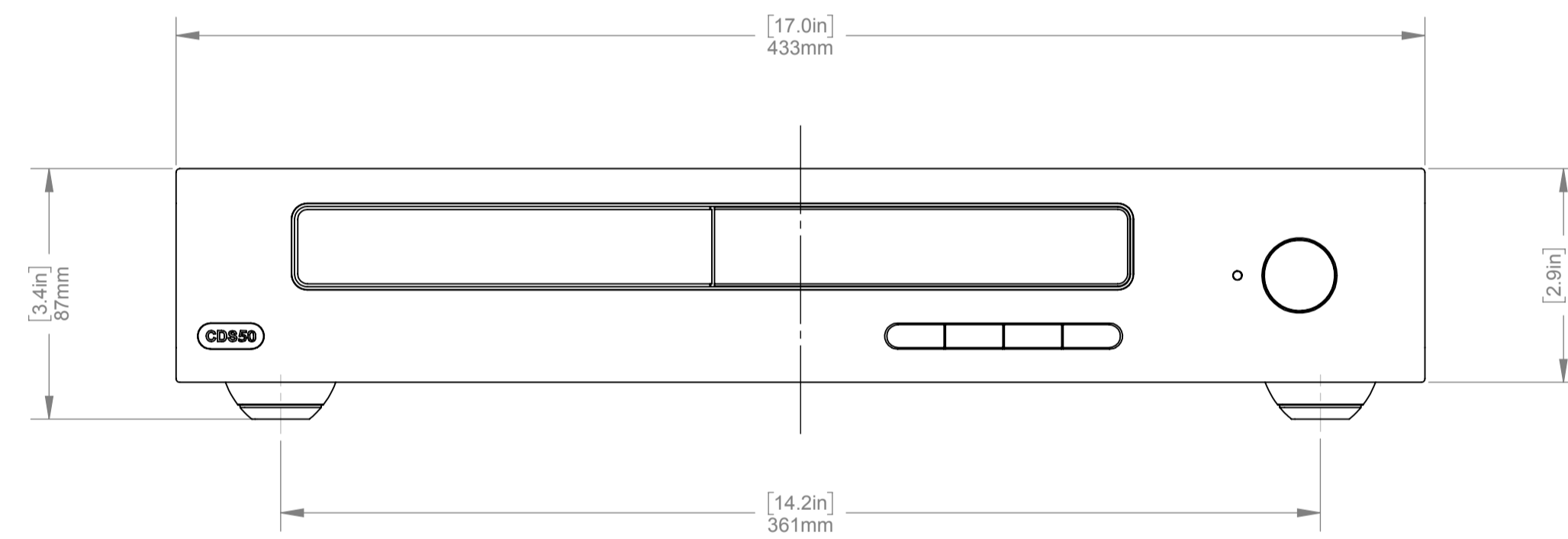
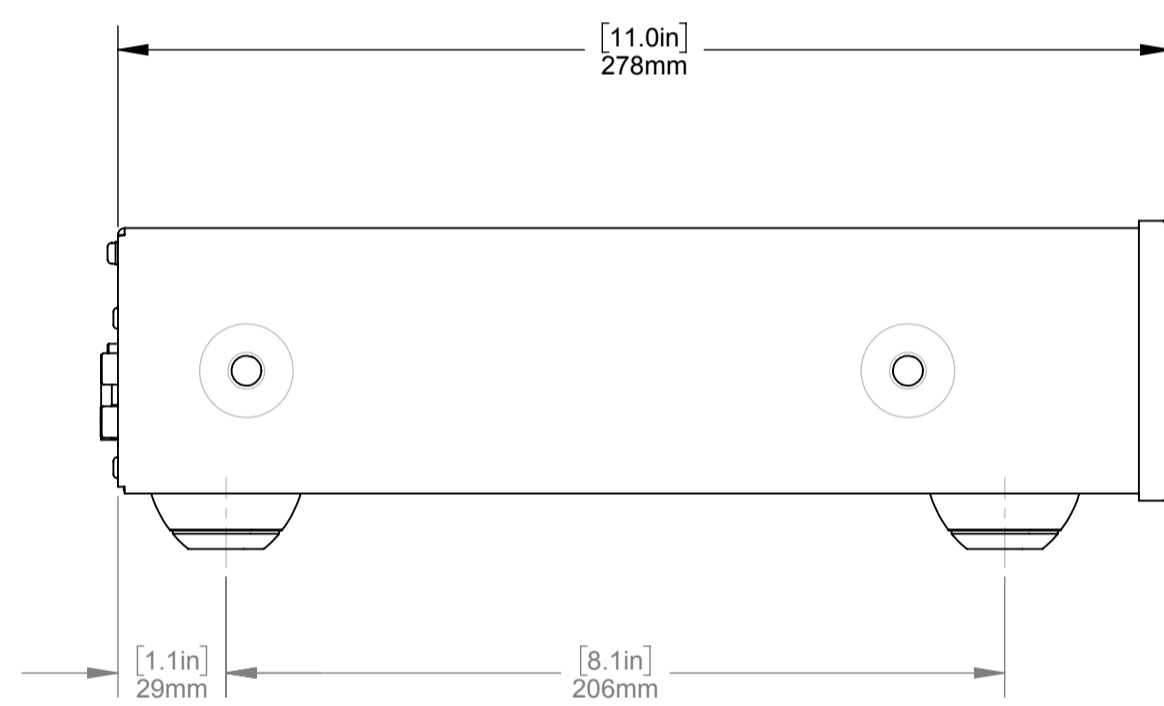
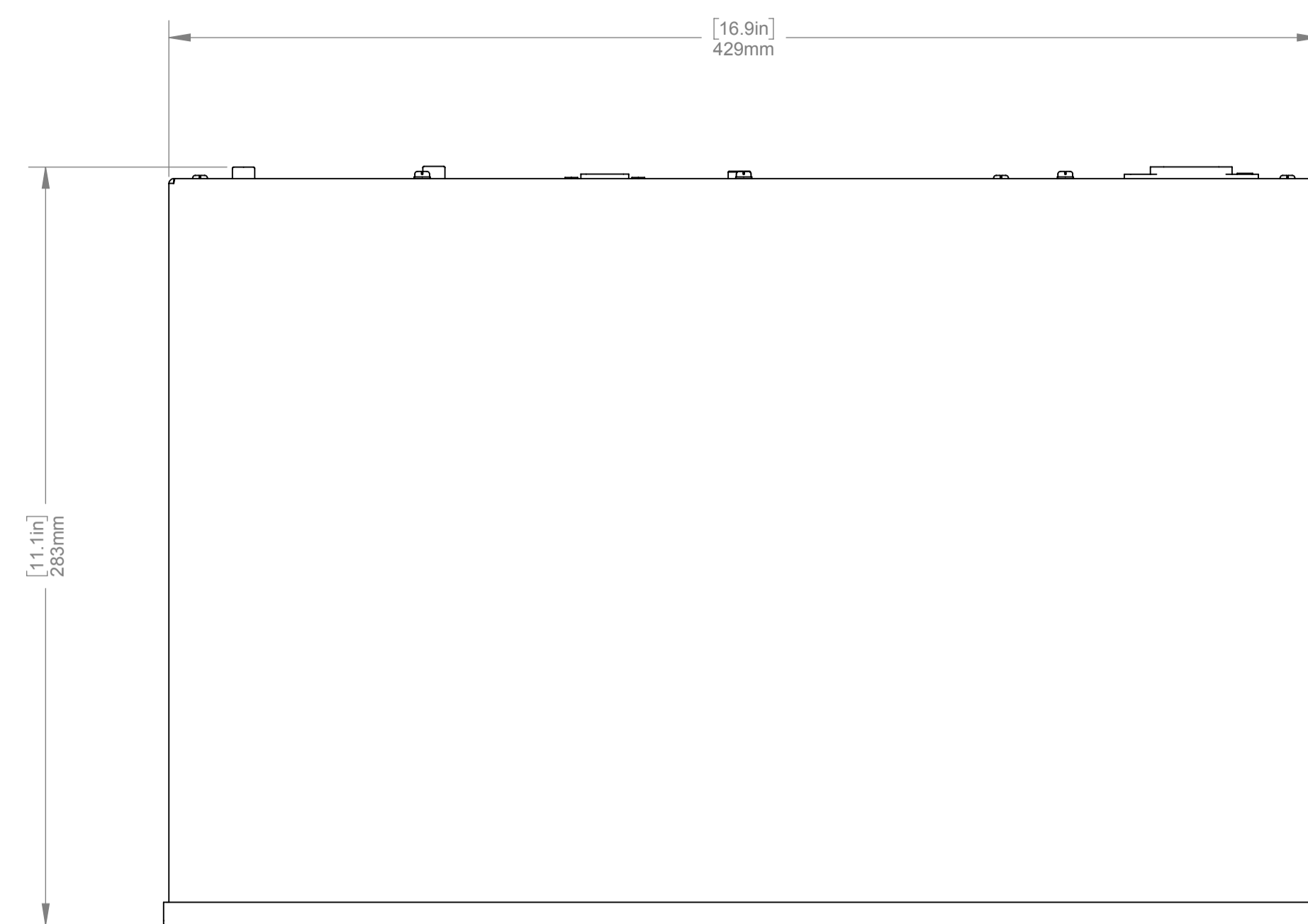
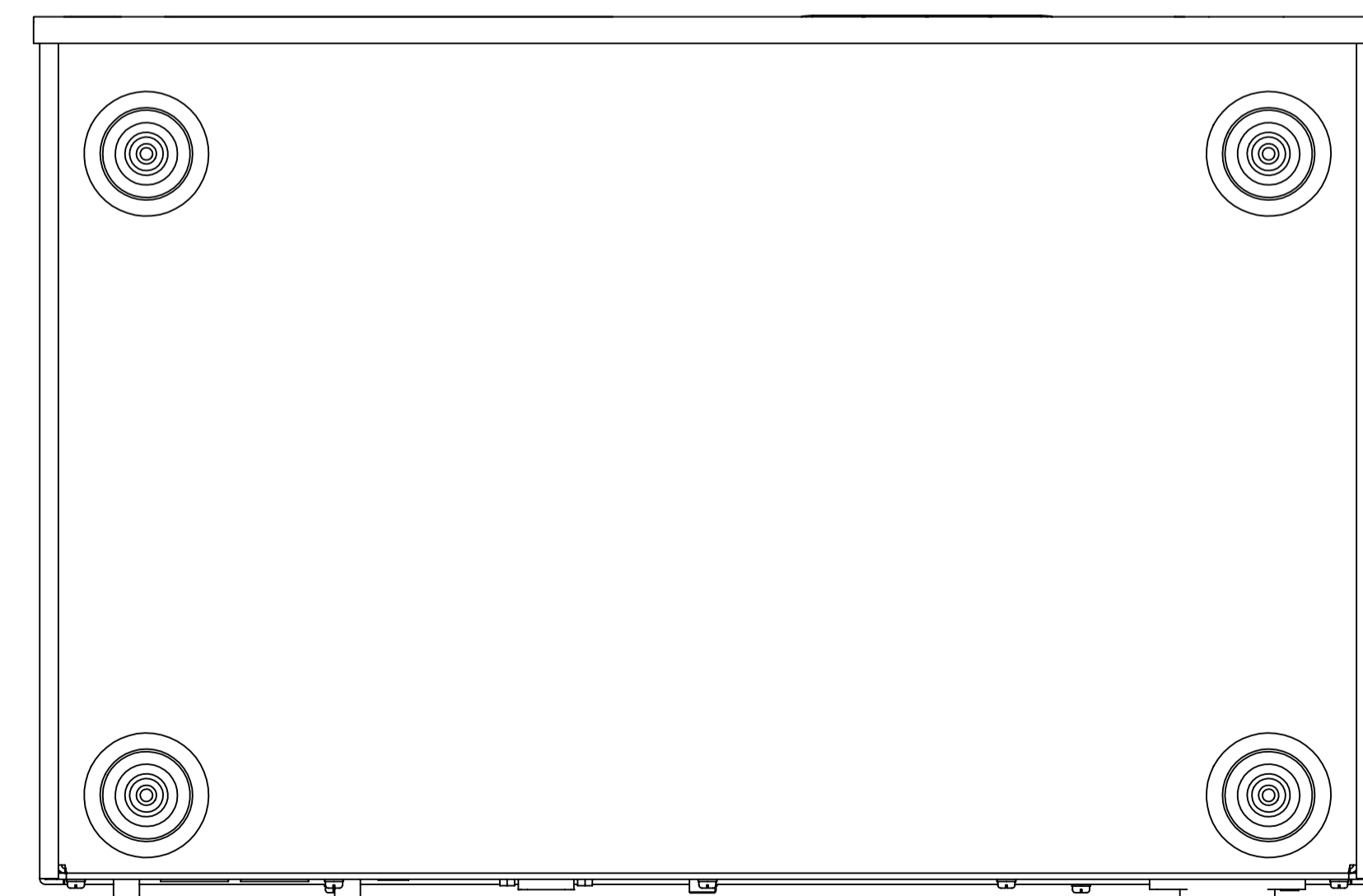

NOTE:

ALLOW ADEQUATE CLEARANCE
AROUND THE PRODUCT FOR
VENTILATION & CONNECTION

ARCAM A & R CAMBRIDGE LTD	DATE:	17-1-2018	DRAWN BY:	MCM
	CHECKED BY:	--		
MATERIAL:		ORIGINAL SCALE 1:2.5		
FINISH:		SHT 1 OF 1		
PART NUMBER AND DRAWING NUMBER		CDS50		
DRAWING TITLE		CDS50 ASSEMBLY		

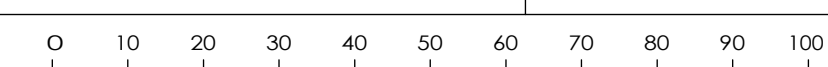

A1